

# PURE

GLOVE BOX WITH  
STAND-ALONE PURIFICATION UNIT  
< 1 PPM H<sub>2</sub>O - O<sub>2</sub>



## PUREEvo

PREMIUM AND FULLY  
CUSTOMIZABLE

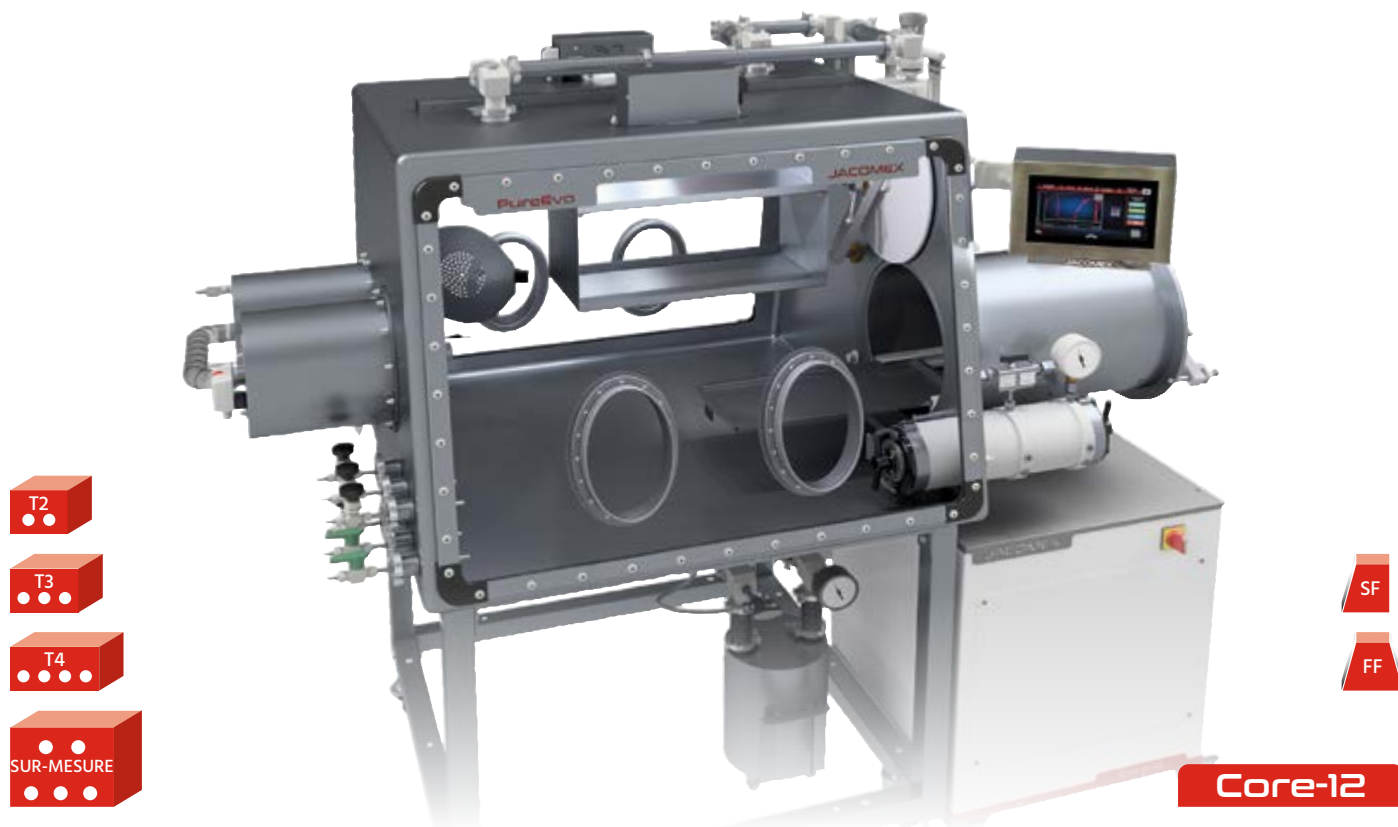

## LIMITLESS CUSTOMIZATION

Design and operating adapted to any specific or complex processes

- ▼ Interconnectable glove boxes modules
- ▼ Customized dimensions and shapes
- ▼ 100% compatible with all options and equipment at JACOMEX
- ▼ Flexible and scalable design.  
Designed for the integration of simple and sophisticated machinery and instrumentation
- ▼ Standard configuration and options
  - **Design:** 100% removable - rounded corners
  - **Surface finish:** satin - electropolished
  - **Stainless steel quality:** AISI 304L - AISI 316L (1.4306) (1.4404)

## PURIFICATION UNIT

- ▼ Single line H<sub>2</sub>O - O<sub>2</sub> stand-alone purification unit
- ▼ Leak rate <10E-5mbar l/s
- ▼ Closed loop circulation - Adjustable flow rate 0-120m<sup>3</sup>/h
- ▼ Automatic regeneration
- ▼ Regeneration N<sub>2</sub> or Ar + 3-10% H<sub>2</sub>
- ▼ Purification capacity **Core-12**
  - 55 L O<sub>2</sub>
  - 1500 g H<sub>2</sub>O
- ▼ Options: double-line H<sub>2</sub>O - O<sub>2</sub> stand-alone purification units

# JACOMEX

- **High Purity and Special Design** adapted to any specific project, scientific and industrial process in development or at pilot stage
- Recommended for mass production and characterisation under pure atmosphere, integration of equipment and machines as well as processes requiring configurable controls, automation and safety.

**24/24 Energy-Saving Mode**  
In standby and in use  
During handling



## TECHNICAL DATA

▼ <b>Tightness Class 1</b> according to ISO 10648-2 (oxygen method) Leak rate <math> < 5.10E-4/h </math> (0.05 Vol%/h)
▼ EPDM gaskets with high chemical resistance
▼ Glovebox - vacuum chamber - piping: stainless steel X2CrNi18-9 (AISI304L)
▼ Programmable automatic vacuum chamber Ø 400 Length 600 mm Inner sliding tray - Removable rails Leak rate <math> < 10E-5\text{mbar l/s}</math>
▼ Front panel: sapphire polycarbonate - laminated mineral glass
▼ Polymer glove rings Ø 220 mm - Antistatic butyl gloves
▼ Lighting from the ceiling (LED spotlights)
▼ 6 stainless steel shelves (height-adjustable)
▼ 1 electrical feedthrough 230V + 6 blank feedthroughs for ISO KF40
▼ Automatic regulation (positive or negative pressure)
▼ Remote stand-alone H <sub>2</sub> O - O <sub>2</sub> purification unit
▼ 10" HD color touch screen: new intuitive menus, integrated assistance, user management, traceability, graphs and alarms...



**NEW INTERFACE 10"**

## ADVANTAGES

- ▼ Flexibility - Ability to integrate equipment and machinery
- ▼ **Customized project management - Information Folder** technical support, 3D drawings simulation, technical and ergonomic setup approval
- ▼ 4 large-capacity purification models available: Core-12, Core-24P, Core-24S, P(sys)-IV  
Processing of larger volumes, severe or tricky conditions, regenerations at widely spaced intervals  
**Purification loads among the most quantitative on the market for equivalent range.**
- ▼ Pressure regulation without vacuum pump (positive pressure/negative pressure)
- ▼ Comfortable to use - **Quiet**
- ▼ Easy and accessible maintenance
- ▼ Long service life - Low operating costs
- ▼ **Hazardous inert atmospheres:** (operating in negative pressure) : address us for designing a fitted security configuration (specific equipment recommended).

## POSSIBLE APPLICATIONS...

- ▼ Materials physics and nanotechnologies
- ▼ Powder processes
- ▼ Development of all-solid-state batteries and lithium alternatives
- ▼ Oven processes (treatment, sintering, annealing)
- ▼ Organic electronic materials: 2<sup>nd</sup> and 3<sup>rd</sup> generation solar cells (thin films, perovskites, multi-junction, DSSC...), Quantum Dots, graphene and 2D materials.
- ▼ Welding of large parts in titanium and alloys for the aeronautical, naval and automotive industries
- ▼ Research and control of experiments on nuclear materials, sensitive to atmospheric components

## NEW HMI INTERFACE - HD 10" DISPLAY: even larger for greater ergonomics

- ▼ Intuitive navigation with a lot of user-friendly menus
- ▼ Adjustable parameters, continuous recording and graphs
- ▼ Integrated PLC assistance and maintenance for clear and optimal operating and ease of use
- ▼ Configurable indicator light. All features on our separate brochure



**PURE**

< 1 PPM H<sub>2</sub>O & O<sub>2</sub>



GLOVE BOX WITH STAND-ALONE PURIFICATION UNIT

SINGLE-LINE PURIFIERS

**CORE-12**

Variable circulation flow: max.120m<sup>3</sup>/h

Capacities : 55L O<sub>2</sub> - 1500g H<sub>2</sub>O

DOUBLE-LINE PURIFIERS

**CORE-24P**

Variable circulation flow : max.120m<sup>3</sup>/h

Capacities: 110L O<sub>2</sub> - 3000g H<sub>2</sub>O

**CORE-24S**

Variable circulation flow: max.120m<sup>3</sup>/h

Capacities : > 280L O<sub>2</sub> - 3000g H<sub>2</sub>O



COMPARED DATA

Technical Data	PURESMART CORE-8	PUREMOD CORE-10	PUREEvo CORE-12	PUREEvo CORE-24P	PUREEvo CORE-24S
St.Steel Glovebox AISI 304L Thickness 3 mm Tightness class 1 ISO 10648-2	✓	✓	✓	✓	✓
Energy-Saving Mode	✓	✓	✓	✓	✓
Operating mode : positive and negative pressure	✓	✓	✓	✓	✓
Vacuum pump 2 stages 21m <sup>3</sup> /h (Limit Press. 5.10-4 mbar)	✓	✓	✓	✓	✓
Automatic vacuum chamber with adjustable parameters	●	✓	✓	✓	✓
Blower with variable flow		✓	✓	✓	✓
Customized project follow-up		✓	✓	✓	✓
Custom Design / Process integration			✓	✓	✓
Glovebox tightness Self-test	●	●	●	●	●
Alarm Inert gas missing/failure	●	●	●	●	●
Double sided working area		●	●	●	●
Adjustable automatic glovebox flushing depending on H <sub>2</sub> O / O <sub>2</sub> -values		●	●	●	●
Heated mini vacuum chamber Ø150 mm		●	●	●	●
Vacuum chamber with interlocked doors Ø400 mm		●	●	●	●
Glovebox Design: high cleanability			●	●	●
Glovebox Design: electropolishing - Surface coating			●	●	●
Purifier by-pass with automatic purification start (auto-start)			●	●	●
Electronic gauge with vacuum-interconnected cycling			●	●	●
Heated vacuum chamber Ø400 mm			●	●	●
HMI Touch Panel size	7"	7"	10"	10"	10"
Modularity - Integration flexibility	+	++	++++	++++	++++

✓ Standard ● Option

# DIMENSIONS AND DESIGN: PURE RANGE

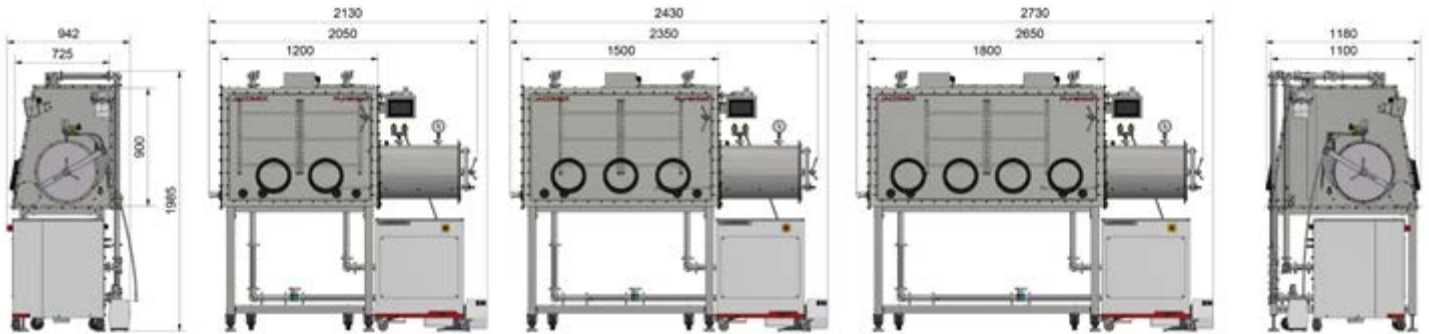

CLASSIC DESIGN

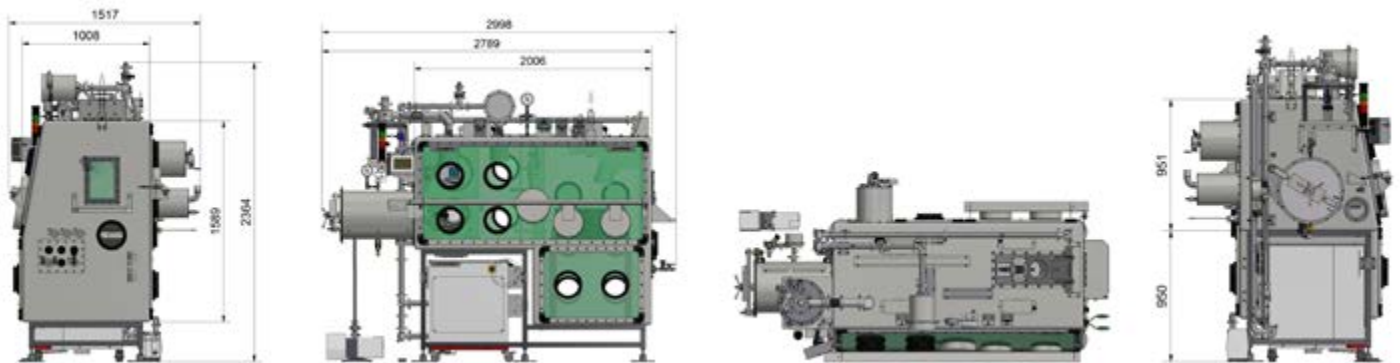

CUSTOM DESIGN (EXEMPLE)

**JACOMEX**  
pure safety

184, Rue du Bicentenaire - Zone Les Prés Seigneurs - 01120 DAGNEUX - FRANCE  
+33 (0) 472 251 900 - contact@jacomex.com - sav@jacomex.com

[www.jacomex.com](http://www.jacomex.com)